



REVIEW

# The contribution of beds to healthcare-associated infection: the importance of adequate decontamination

E. Creamer<sup>a,\*</sup>, H. Humphreys<sup>a,b</sup>

<sup>a</sup> Department of Clinical Microbiology, Education and Research Centre, Royal College of Surgeons in Ireland, Dublin, Ireland

<sup>b</sup> Department of Microbiology, Beaumont Hospital, Dublin, Ireland

Available online 19 March 2008

## KEYWORDS

Beds; Mattresses;  
Pillows; Bed  
accessories;  
Decontamination;  
Outbreaks

**Summary** The hospital bed is comprised of different components, which pose a potential risk of infection for the patient if not adequately decontaminated. In the literature there are a number of descriptions of outbreaks or experimental investigations involving meticillin-resistant *Staphylococcus aureus*, vancomycin-resistant enterococci, *Acinetobacter* spp., and other pathogens. Often only the bedrail has been sampled during investigation of outbreaks, rather than more important potential reservoirs of infection, such as mattresses and pillows, which are in direct contact with patients. It is essential that these items and other bed components are adequately decontaminated to minimise the risk of cross-infection, but detailed advice on this aspect is often lacking in reports and official documents. Clear guidelines should be formulated, specifying the decontamination procedure for each component of the bed. In outbreaks, investigation should include an assessment of mattresses and pillow contamination as a critical aspect in outbreak management.

© 2008 The Hospital Infection Society. Published by Elsevier Ltd. All rights reserved.

## Introduction

Microorganisms have been isolated from different environmental sites in hospital but relatively little is confirmed about the association of the environment in the spread of infection. Cleaning and hygiene are emphasised to minimise bacterial

\* Corresponding author. Address: Department of Clinical Microbiology, RCSI Education and Research Centre, Beaumont Hospital, PO Box 9063, Beaumont Road, Dublin 9, Ireland. Tel.: +353 1 8093748/3708; fax: +353 1 8093709.

E-mail address: [eilishcreamercsi.ie](mailto:eilishcreamercsi.ie)

contamination of the environment. Even with apparently adequate cleaning and disinfection, however, there are reports of prolonged outbreaks and difficulty with control measures. Whereas some environmental aspects such as mattresses and pillows are of higher risk due to their direct contact with patients, others, e.g. walls, lights, floors, are more remote and probably of lesser risk. Most reports on the investigation of the hospital environment have mainly focused on outbreak control of methicillin-resistant *Staphylococcus aureus* (MRSA), vancomycin-resistant enterococci (VRE), *Acinetobacter* spp., *Clostridium difficile* and *Pseudomonas* spp. Experimental studies on bed contamination are relatively scarce and the significance of bed contamination has not usually been highlighted in reports. Bed components including bedframes and mattresses may become contaminated by microorganisms through direct contact with skin scales, body fluids including urine and faeces, and thus become a source of infection.<sup>1,2</sup>

In evaluating scientific reports and studies in this area, methodological differences and lack of standardisation make interpretation difficult. Information on contextual issues such as the relevance of findings to endemic and ongoing

outbreaks, or if standard infection control precautions were implemented, are often lacking. Aspects not routinely addressed include: cleaning methods used; whether clean water and cleaning cloths were used; disinfectant concentration; time lapse between disinfection and sampling, rinsing and drying of materials after disinfection; the physical nature of mattress, pillow and bedframe materials; the incorporation of antibacterial agents including copper and silver in the materials; and the laboratory methods used in the investigation.

In this review we examine the significance of bed contamination and its disinfection as an important aspect in the prevention and control of healthcare-associated infection.

## Definitions

The hospital bed (Figure 1) consists of a bedframe, mattress, pillows and bedclothes.<sup>1,2</sup> The bedframe includes the hydraulics or electromotor, elevation levers and accessories attached, e.g. bed rails, and lifting poles or hoists. The bedframe and accessories are usually made of metal, steel or equivalent. Newer beds usually have an open

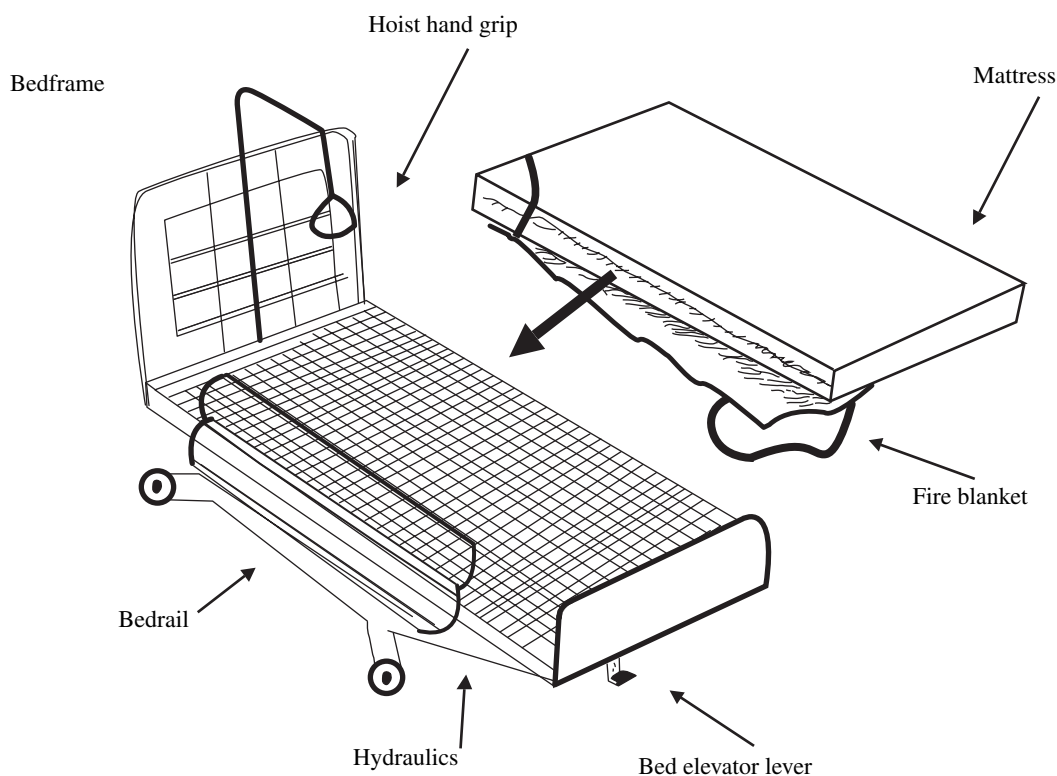

Figure 1 Hospital bed, including accessories and mattress.

**Table I** Research/experimental studies of the spread of pathogens by aerial and other routes, associated with bed components and other environmental aspects

Reference	Year	Location	Bedframe	Bedrail	Mattress	Pillow	Linen	Other aspects	Pathogen	No. of bed component samples tested	Intervention	Outcome
11	1988	15 unoccupied single rooms	—	—	—	—	a	a	<i>Bacillus stearothermophilus</i> <sup>b</sup>	15/15	Inoculation of clean bed linen with test organism; air, contact sampling before, during, after bed making	Test organism in air, increased during bed making (15/15), but less (6/15) after — suggestive of aerial spread during bed making
12	1996	8 cystic fibrosis patients having physiotherapy	—	—	—	a	—	a	<i>Burkholderia cepacia</i>	5/17	Air and surface sampling before, during and after physiotherapy	Organisms isolated in air, during, after physiotherapy and pillows — suggestive of aerial spread
13	2006	25 MRSA patients in isolation rooms	a	—	a	—	a	a	MRSA	132/252	Weekly sampling after admission to isolation room	MRSA isolated in environment, beds, mattresses and in air — suggestive of aerial spread
14	2002	13 MRSA isolation rooms	—	—	—	—	a	a	MRSA	NS	Air and surface sampling before, during and after bed making and environmental sampling	Test organism isolated in air, environment, bed linen — suggestive of aerial spread
15	2005	12 single room cystic fibrosis unit	—	—	—	—	a	a	<i>Pseudomonas aeruginosa</i>	2/8	Sampling patients and environment	Transient carriage of organisms in patient's immediate environment and bed linen. Air samples positive — suggestive of aerial spread

16	2005	Used cot mattresses: home	—	—	—	—	—	—	10/29	Simulation head movement on mattresses, air sampling	Simulated movement increased the level of organisms in air released from mattresses — suggestive of aerial spread
17	1962	2 surgical wards: 15 and 10 beds	—	—	—	—	—	a	314/1394	Evaluation of environmental disinfection and air recirculation system, sampling air, blankets	Air recirculation system reduced organisms in air, disinfection did not reduce blanket contamination — suggestive of aerial spread

MRSA, methicillin-resistant *Staphylococcus aureus*; NS, not specified.  
 a Bed component sampled.  
 b Test organism.

mesh base to allow air to circulate between the base and the mattress, and thereby prevent the build-up of moisture, although solid base beds may still be in use.<sup>3</sup>

Mattresses are usually made of foam, while the mattress cover is normally made of synthetic material, e.g. polyurethane, vinyl, polythene, polyester.<sup>4</sup> The cover should be impermeable to fluids, but permeable to vapour.<sup>3</sup> Many mattress covers are now impregnated with antibacterial agents that are purported to prevent bacterial growth. It is difficult to determine the disinfectant properties of these agents and their effectiveness in preventing bacterial growth. Currently there is interest in newer products to inhibit bacteria such as silver.<sup>5</sup>

Additional bed covers may occasionally be used over that supplied to encase the mattress. Pressure-relieving mattresses may also be placed on top of the supplied mattress. These provide an air-alternating tube system that is connected to a mechanical pump at the mattress base. They are usually covered with an impermeable or washable cover. Other pressure-relieving beds, e.g. air-loss and air-fluidized beds, are also available and require special decontamination measures, as recommended by the manufacturer.<sup>6,7</sup>

Pillows generally consist of an inner foam or synthetic filling encased in a PVC, plastic, vinyl, or polyester impermeable cover. Pillow cover materials may also be impregnated with an antibacterial agent. The seams of the cover may be stitched or welded. Pillows are encased in a laundered pillow cover, when in use.

Bed linen consisting of sheets, blankets and a bedcover are usually of cotton cellular or cotton and synthetic material. Duvets are usually made of a fibre filling and are usually encased in a washable or impermeable cover.

As a safety measure, fire blankets, usually made of nylon-type material, are placed under the mattress to assist with evacuating patients in case of fire. They are fitted with straps and may have metal fittings for securing around the mattress and pulling the patient in the mattress to safety.

### Research/experimental and observational studies

The transmission of infection from the environment to patients is mainly through contact, particularly via hand contact, but aerial transmission is also likely.<sup>8</sup> Environmental contamination is reported to be increased if wounds or urine are

**Table II** Survey of bed components and other environmental aspects

Reference	Year	Location	Patients affected	Bedframe	Bedrail	Mattress	Pillow	Linen	Other aspects	Isolate	No. of bed component samples tested	Intervention related to environment	Environmental outcome
18	2006	Burns unit	NS	—	—	—	<sup>a</sup>	—	—	<i>Acinetobacter</i> and other organisms	3/3	Sampling pillows	Organisms isolated. Replacement with disposable pillows
19	1988	Burns unit, ICU	NS	—	—	<sup>a</sup>	—	—	—	<i>Acinetobacter</i> and other organisms	15/29	Inspection, sampling mattresses	Regular inspection and replacement of damaged mattresses
20	2006	Donated pillows – home	NS	—	—	—	<sup>a</sup>	—	<sup>a</sup>	<i>Aspergillus</i> – various species	69/10	Investigation of contamination – sampling pillows	Organisms isolated from pillows
21	2002	HIV patients in 2 hospitals	207 patients recruited	—	<sup>a</sup>	—	—	—	<sup>a</sup>	<i>Clostridium difficile</i>	9/NS	Sampling environment monthly, including bedrails	9 bedrails contaminated. Environment not cause of outbreak
22	2003	Care of elderly wards	NS	<sup>a</sup>	—	—	—	—	<sup>a</sup>	<i>Clostridium difficile</i>	NS	Investigation of environmental decontamination using detergent or a hypochlorite disinfectant	~50% bedframes contaminated
23	2004	Surgical wards	23 Non-MRSA patients	<sup>a</sup>	—	—	—	—	<sup>a</sup>	MRSA	10/23	Sampling before, after terminal cleaning and after hydrogen peroxide fumigation	Cleaning ineffective, whereas hydrogen peroxide effective in eliminating organisms
9	1997	MRSA isolation rooms	38 patients, 22 infected	—	<sup>a</sup>	—	—	<sup>a</sup>	<sup>a</sup>	MRSA	NS	Sampling of environment of MRSA patients	Bedrails <30% MRSA positive, bed linen ~55% approx.
24	2000	General wards	NS	—	—	<sup>a</sup>	—	—	—	<i>Staphylococcus aureus</i>	500/1040	Sampling mattress covers pre and post disinfection with phenolic	Organisms isolated – failure of decontamination procedure

25	2003	MICU	63 patients, 3 infected (1 BSI, 1 UTI, 1 IV)	—	<sup>a</sup>	—	—	—	<sup>a</sup>	VRE	NS	Enhanced cleaning	After institution of more thorough cleaning, no VRE isolated
26	1998	Isolation rooms	NS	—	<sup>a</sup>	—	—	—	<sup>a</sup>	VRE	60/NS	Disinfection by wetting for 10 min instead of spraying	Spraying with disinfectant less effective than 'wetting'
10	1996	MICU	19/95 patients colonised	—	<sup>a</sup>	—	—	<sup>a</sup>	<sup>a</sup>	VRE	30/NS	Daily sampling of patients and environment	VRE isolated from bedrails and drawsheets
27	1995	Experiment: volunteer hands, environmental surfaces	NA	—	<sup>a</sup>	—	—	—	<sup>a</sup>	VRE	NS	Sampling surfaces after disinfection: quaternary ammonium compound	Organisms survived 5 days on counter tops, 24 h on bedrails
28	2007	<i>C. difficile</i> , VRE isolation rooms	19 VRE, 9 <i>Clostridium difficile</i> patients	—	<sup>a</sup>	—	—	—	—	VRE, <i>Clostridium difficile</i>	NS	Environmental sampling pre and post cleaning, disinfection by research staff — education of cleaning staff	Organisms on bedrails reduced when cleaned by cleaning staff

NS, not specified; NA, not applicable; ICU, intensive care unit; HIV, human immunodeficiency virus; MRSA, meticillin-resistant *Staphylococcus aureus*; MICU, medical intensive care unit; BSI, bloodstream infection; UTI, urinary tract infection; IV, intravascular infection; VRE, vancomycin-resistant enterococcus; MICU, medical intensive care unit.

<sup>a</sup> Bed component sampled.

colonised with MRSA, and in cases where more body sites are colonised.<sup>9,10</sup> There are some studies, varying in quality and experimental approach, that have tried to address the issue of the transmission of infection. Studies involving bed components associated with aerial transmission are summarised in Table I.<sup>11–17</sup> Other surveys and studies, varying between outbreak and intervention reports, are shown in Table II.<sup>9,10,18–28</sup>

In an experimental study conducted in isolation rooms, MRSA was isolated from mattresses, bedframes and air, and isolates were similar to the patients' strains, suggestive of contact and aerial spread.<sup>13</sup> *Pseudomonas aeruginosa* was isolated from air samples, bedclothes, pillows and other sources when investigating an endemic situation in a UK cystic fibrosis unit.<sup>15</sup>

Bed making has been associated with the aerial dispersal of organisms.<sup>11,14,17</sup> In an experimental study of aerial transmission, pyogenic staphylococci were isolated from air and blankets in an experimental and control ward.<sup>17</sup> Other studies on bed making, using a strain of MRSA, and a test organism *Bacillus stearothermophilus*, yielded increased colonies after bed making, but colony counts fell by 30 min after bed making to pre-bed-making levels.<sup>11,14</sup> These studies suggest that airborne transmission plays a significant role in cross-infection.

Consequently, precautions to minimise spread are essential, such as by physical segregation of colonised and infected patients, hygiene, and the scheduling of ward aseptic procedures to minimise airborne spread to nearby surgical sites. Further reduction may be possible by the use of artificial ventilated systems. There is little independent study, apart from internal company assessments, on the incorporation of antimicrobial finishes to mattress and pillow materials and the impact that these may have on reducing bacterial contamination. The antimicrobial effect of copper and brass, in contrast to stainless steel, was demonstrated after experimental inoculation of MRSA.<sup>29</sup>

More research is required on aerial and contact spread of organisms and the influence that the organisation of patterns of work has on minimising the dispersal of airborne organisms, associated with beds and their components.

## Outbreaks associated with bed contamination

Various environmental sources have been sampled during outbreaks and endemics (Table III).<sup>30–46</sup> In

many cases, the bedrail and other sites not directly in contact with the patient were sampled, instead of the mattress or pillow which would be in direct contact with patients. Consequently, a clear focus of investigation was often not apparent, and important reservoirs may have been missed and outbreaks prolonged as a result.

## Mattress contamination

Mattress contamination with various organisms has been reported in a number of studies and outbreaks.<sup>13,24,32,33,35–44,46</sup> Mattresses can be damaged by extensive use, tears and by sharp objects such as needles penetrating them. Damaged and wet mattresses have been found to be the source of contamination during outbreaks.<sup>33,37–42</sup> An audit of mattresses indicated that a large number were permeable and required replacement.<sup>47</sup> However, the screening of the mattress covers for pathogens causing outbreaks may not be a reliable indication of contamination, especially if damaged. Cleaning or disinfection and drying may remove organisms from the mattress cover, while the inner wet foam may still harbour bacteria that can ooze out when a patient lies on the mattress or the mattress is physically pressed.<sup>40,41</sup>

## Pillows

While pillows have been linked to contamination, it is somewhat surprising that there are few reports of an aspect in such direct or close patient contact.<sup>12,18,20,30,34,36</sup> In a survey of pillows in a burns unit, pillow seams and label inserts allowed organisms to enter the pillow core.<sup>18</sup> Feather pillows have been associated with *Acinetobacter* sp.<sup>30</sup> In a study of allergy related to pillows, several fungal species were isolated, the commonest being *Aspergillus fumigatus*, with more species and growth from synthetic rather than feather pillows.<sup>20</sup> It was suggested that the closer weave of the feather pillow cover may reduce contamination.

## Bedframes and bedrails

Bedframes and bedrails, along with other environmental sources, have also been sampled during surveys and outbreaks.<sup>9,10,21,22,23,25–28,31,32,35–37,45,46</sup> Bedrails were likely to have been sampled because they were considered an indicator of contamination, as outlined in the Hospital Infection Control Advisory Committee (HICPAC) guidelines

**Table III** Outbreaks of infection associated with bed components and other environmental aspects

Reference	Year	Location	Patients affected	Bedframe	Bedrail	Mattress	Pillow	Linen	Other aspects	Pathogens	No. of bed component samples tested	Interventions	Duration outbreak	Outbreak terminated
30	1995	ICU, general wards	137 patients colonised, 110 infected	—	—	—	a	—	a	<i>Acinetobacter</i> spp.	36/51	Replacement pillows, washing synthetic pillows	36 months	Yes
31	2004	Neurosurgical ICU	19 patients colonised or infected	a	—	—	—	—	a	<i>Acinetobacter baumannii</i>	NS	Improved cleaning	14 month	Yes
32	1999	ICU	15 patients colonised or infected, 10 pneumonia, 2 IV bacteraemia	—	a	a	—	—	a	<i>Acinetobacter baumannii</i>	3/32 <sup>b</sup>	Hand hygiene, cohorting, sampling focused on bed components	3 months	Yes
33	1985	Burns unit	63 patients colonised, 43 infected	—	—	a	—	—	a	<i>Acinetobacter calcoaceticus</i>	5/8	Infection control precautions, replacement mattresses	21 months	Yes
34	2005	Staff homes	14 staff, 11 household contacts	—	—	—	a	a	a	MRSA	2/NS	Decontamination of staff homes	24 months	Yes
35	2001	Surgical ward	69 patients	a	a	a	—	—	a	MRSA	6/128	Hand hygiene, isolation and infection control precautions, closure areas, enhanced cleaning	27 months	Yes
36	1998	MRSA isolation rooms	41 patients	a	a	a	a	—	a	MRSA	25/41	Sampling rooms after discharge and cleaning, enhanced cleaning, replacement carpets	NS	NS

(continued on next page)



Table III (continued)

Reference	Year	Location	Patients affected	Bedframe	Bedrail	Mattress	Pillow	Linen	Other aspects	Pathogens	No. of bed component samples tested	Interventions	Duration outbreak	Outbreak terminated
37	1993	General wards	64 patients, 6 staff, 30 patients colonised, 34 infected	a	—	a	—	—	a	MRSA	NS	Isolation, replacement mattresses, pillows, enhanced cleaning	36 months	Yes
38	1991	Antenatal, Postnatal wards	37 colonised or infected mothers, 18 babies, 9 staff	—	—	a	—	—	a	MRSA	2/12 <sup>b</sup>	Outbreak control measures, closure wards, enhanced cleaning, replacement mattresses	6 weeks	Yes
39	1991	Post-natal ward	82 mothers, 28 babies: 46 episiotomy incisions, 23 vaginal discharge, 9 UTI, 3 wound, 2 breast abscess, 8 babies conjunctivitis	—	—	a	—	—	a	MRSA	NS	Hand washing, isolation, enhanced cleaning, replacement of damaged mattresses	12 months	Yes
40	1981	Burns unit	66 patients	—	—	a	—	a	a	<i>Pseudomonas</i> spp.	3/8	Replacement mattress and restriction use silver nitrate	20 months	Yes
41	1980	Urology theatre	6 patients: postoperative UTI	—	—	a	—	—	—	<i>Pseudomonas</i> spp.	1/1	Replacement mattress	6 weeks	Yes

42	1992	Orthopaedic ward	10 patients: wound infection	—	—	<sup>a</sup>	—	—	—	<i>S. aureus</i> , <i>E. faecium</i> , <i>Pseudomonas</i> spp., coliforms	5/5	Replacement of five mattresses	6 weeks	Yes
43	1991	Neonatal ICU	27 babies with gastroenteritis, 4 bacteraemia, 9 babies died, 1 staff carrier			<sup>a</sup>	—	—	—	<i>Salmonella wein</i>	1/NS	Hand washing, treatment of staff carrier, infection control precautions, disinfection unit, replacement of mattresses	5 months	Yes
44	2002	Renal wards	59 (13%) patients colonised	—	—	<sup>a</sup>	—	—	<sup>a</sup>	VRE	35/433	Enhanced cleaning, twice disinfection	20 weeks	Reduced
45	1998	ICU	296 patients colonised, 63 (18%) infected (11 BSI, 26 SSI and soft tissue, 4 peritonitis, 2 pelvic abscess, 22 UTI)		<sup>a</sup>	—	—	—	<sup>a</sup>	VRE	NS	Hand hygiene, isolation, antibiotic restriction, enhanced cleaning	39 months	Reduced
46	1998	Isolation rooms	2 patients: 1 UTI	—	<sup>a</sup>	<sup>a</sup>	—	—	<sup>a</sup>	VRE	NS	Rectifying toilet blockage, twice cleaning, disinfection	NS	Yes

ICU, intensive care unit; NS, not specified; MRSA, methicillin-resistant *Staphylococcus aureus*; UTI, urinary tract infection; VRE, vancomycin-resistant enterococcus; BSI, bloodstream infection; SSI, surgical site infection; IV, intravascular infection.

<sup>a</sup> Bed component sampled.

<sup>b</sup> Or more.

from the USA.<sup>48</sup> They may be considered a risk because incontinent patients may inadvertently contaminate the bedrail.<sup>27</sup> In an experimental study, use of a fluorescent compound highlighted ineffective cleaning of bedrails by cleaning staff.<sup>49</sup> VRE has been reported to survive on bedrails for 24 h.<sup>27</sup> Another investigator reported only transient VRE after disinfection with a phenolic disinfectant.<sup>10</sup> This suggests that cleaning and disinfection are usually adequate for decontaminating bedframes and bedrails, if carried out effectively.

### Linen

Bed linen has been associated with contamination.<sup>9,10,13–15,17,34,40</sup> Clean linen and linen racks have been found contaminated with *S. aureus* and MRSA, which emphasises the need for cleaning, separate storage and careful handling.<sup>50</sup>

### Fire blankets

Contamination of fire blankets does not appear to be reported in the literature, but the potential exists from contaminated mattresses and beds. Fire blankets need to be laundered or decontaminated between patients, when and if used.

### Risk assessment, guidelines and cleaning

Different levels of infection risk apply to various components of beds, e.g. mattress, pillow, bedframe, depending on their use for which category of patients, e.g. routine use, infection risk patients, during outbreaks or endemic situations. Normally, the mattress and pillow should be considered higher risk than the bedframe, because the patient is in direct contact with the mattress and pillow. Allowance is necessary for the degree of contamination that can occur if a patient is incontinent, with the risk of leakage of urine or faeces into the mattress, especially if the mattress is worn or damaged. There is an added risk if there is contamination with MRSA, VRE, and organisms that have been reported as not being readily eradicated with cleaning or disinfectants.<sup>51</sup> In contrast, the bedframe and bedrails are more likely to be effectively decontaminated routinely because they consist of smooth materials, e.g. metal, steel or equivalent, whereas, the material covers of the mattress and pillows are less easily decontaminated.

Staff may sometimes not be aware of the risks associated with bed decontamination; the cleaning and disinfection may not be done correctly, an incorrect concentration of disinfectant may be used, or beds may not be cleaned at all.<sup>28</sup> A number of staff may be involved in the cleaning process, such as nurses, healthcare assistants, cleaners, all cleaning different components of the bed, without clear delineation of roles and responsibilities.

### Guidelines

Guidelines for bed decontamination have been provided in infection control text books, nursing, and medical literature, and have been published by North American authorities.<sup>1,2,4,39–42,52–54</sup> The HICPAC guidelines on environmental infection control provide a section on bed decontamination, and the CDC guideline for containment of communicable disease emphasises environmental decontamination, providing examples such as 'bed rails' and other aspects, but without emphasising the mattress or pillow.<sup>53,54</sup> However, government healthcare agencies such as the Medical Devices Agency in the UK, and the Irish Medicine Board, have issued 'alert notices' and made recommendations, often in response to outbreaks or adverse events.<sup>55–57</sup>

### Cleaning and disinfection of beds

The Medical Devices Agency in the UK has recommended that beds, mattresses and pillows receive adequate decontamination.<sup>56</sup> The ideal is to heat-disinfect all components, which may be standard practice in northern European countries but is not practical with the high turnover of patients and the current lack of space in many other countries. Alternative technology is now available, such as hydrogen peroxide fumigation, but there is a time element (up to 5 h or more) and the system has not yet been validated for routine use.<sup>23</sup> Disposable mattress covers are available but the smooth-textured surface may allow the patient to slip. Therefore, in most instances simple cleaning and disinfection must be employed.

Washing with soap and water removes most bacteria and is suitable for routine use.<sup>1</sup> Disinfectants are even more effective in removing bacteria.<sup>1</sup> However, some argue that the routine use of disinfectants on environmental surfaces achieves little and is not recommended, and there is the possibility of selective pressure on bacteria to

become resistant to disinfectants.<sup>1,58</sup> Nonetheless, there are specific situations where environmental contamination does represent a significant risk of spread of infectious agents, e.g. in outbreaks or for specific communicable diseases, and therefore a disinfectant should be used.

### **Bedframe, mattress and pillow decontamination**

Bedframes and mattresses may be cleaned with hot water and detergent using a clean bowl with disposable paper towels or a disposable cloth followed by thorough drying.<sup>1,4,52</sup> Detergent-impregnated surface wipes are available but their efficacy is unknown, although such wipes are recommended in the HICPAC environmental hygiene guidelines.<sup>52,53</sup>

Where solid-base beds are used, it is important that the base is dried before the mattress is replaced as moisture may be retained between the base and the mattress causing degradation of the mattress cover and the potential for the proliferation of organisms.<sup>3</sup> A notice or label is necessary to indicate that the bed has been decontaminated and when. The bed should be covered with a disposable or laundered cover for transportation to a decontamination facility.<sup>2</sup> Unoccupied beds must be covered after decontamination.

### **Frequency of cleaning**

There was no consensus in the past about how often bedframes should be cleaned, but regular cleaning was advised, and also when the bedframe was contaminated.<sup>1,2</sup> However, it is now recommended that the bed, including the frame and mattresses, should be decontaminated between each patient, and once a week if the bed is occupied by the same patient.<sup>4,52,59</sup>

### **Disinfection agents**

The effectiveness of disinfectants may be reduced depending on the organism, organic matter, materials sampled, host factors and how used by staff. Where disinfection is required, a hypochlorite disinfectant is generally recommended, because it is less likely than other disinfectants, such as phenolics or alcohols, to damage mattress covers.<sup>1</sup> Following the use of a hypochlorite, thorough rinsing with fresh water is advised to minimise the corrosive effects of the disinfectant.<sup>1</sup> Phenolics have been used for mattress contamination during outbreaks and found to be generally

effective.<sup>25</sup> Quaternary ammonium compounds have also been used but with variable results when used in outbreak situations, especially in eradicating VRE.<sup>26,28</sup>

### **Concentration of disinfectant**

If disinfection is considered necessary, a chlorine-releasing agent (1000 ppm available chlorine, or clear soluble phenolic) is usually considered suitable.<sup>1</sup> Whereas a hypochlorite concentration of 10 000 ppm available chlorine is recommended to inactivate blood-borne viruses, the effectiveness of lesser concentrations, e.g. 1000 ppm available chlorine used to eradicate other pathogens such as MRSA and VRE on mattresses, is less clear. In one experimental study of survival of norovirus on melamine, prior cleaning with detergent and water, followed by a hypochlorite disinfectant, 5000 ppm available chlorine, was more effective than detergent and water or using a disinfectant alone.<sup>60</sup>

### **Disinfection method**

Disinfection methods involve spraying, wiping or wetting environmental surfaces and immediately wiping with a paper towel and drying. While excessive wetting is not recommended, more effective decontamination of VRE with thorough wetting instead of spraying with quaternary ammonium compound disinfectant has been reported.<sup>1,26</sup> In an experimental study of environmental contamination, cleaning cloths used on a contaminated surface possibly transferred organisms to other surfaces and to the hands of personnel.<sup>60</sup>

### **Testing mattresses for impermeability**

It is important that mattresses are audited and inspected regularly for damage and replaced when necessary.<sup>52,56,57</sup> Six-monthly inspection has been recommended, but this may not be sufficient.<sup>19</sup> Depending on the risk to patients, monthly or quarterly inspection and auditing may be adequate if weekly review is not feasible. Factors to consider include: age, wear and use of the mattress; if used on a high-risk patient group, e.g. incontinent patients; or if there is endemic MRSA, VRE or other organisms. Both sides of the mattress and cover must be inspected to detect any signs of wear, tears, staining, or loss of impermeability.<sup>52</sup> Surface discoloration and blackening are indications of a damaged mattress cover and potential leakage

of fluid into the inner core of the mattress, which can facilitate the harbouring of micro-organisms and is a potential cause of cross-infection.<sup>56</sup> The mattress cover can be tested by unzipping the zip and placing a paper towel inside, pouring a small amount of water over the outside cover and inspecting for leakage into the paper towel.<sup>52</sup> If the water test fails and there is staining, the mattress should be replaced, but if there is no staining of the inner core, then the mattress cover should be replaced. The mattress core may be contaminated by potential pathogens even if there is no evidence of staining. Therefore, if mattress covers are damaged and there is doubt about bacterial contamination of the mattress core, then the whole mattress should be replaced. Mattresses can be turned to reduce excessive wear in any one area.<sup>47</sup>

### Special pressure-relieving mattresses and beds

Special pressure-relieving mattresses and air-fluidised beds are used for patients who are immobile and who are at risk of pressure sores. Apart from one report, there is little in the scientific literature linking alternating pressure-relieving mattresses with contamination, possibly because they are not differentiated from standard mattresses when sampling is undertaken.<sup>35</sup> Pressure-relieving mattresses need to be cleaned and disinfected between patients or at weekly intervals when used by a single patient.<sup>4</sup> The manufacturer's instructions should be followed for decontamination. Other pressure-relieving mattresses, such as air-fluidised beds, have been associated with bacterial contamination, even when the manufacturer's instructions for decontamination had been followed.<sup>6</sup> Nonetheless, it is essential to adhere to HICPAC guidelines, or national equivalent, and to ensure that the supplier's instructions for decontamination are followed. In addition, newer special type beds and mattresses should be monitored for contamination.<sup>53</sup> If hospital mattresses or beds are leased, the supplier should be informed by the hospital if the bed was used on infectious patients as additional decontamination measures may be required.

### Pillows

Pillows should be covered with an impermeable cover and be suitable for laundering, cleaning or disinfection. For routine use, they should be washed with detergent and water and dried. Ideally the actual pillows should be laundered in

a disinfection cycle at 71 °C for 3 min or 65 °C for 10 min.<sup>1</sup> However, difficulties may be encountered in decontaminating pillows. The manufacturer's instructions should always be observed, but before purchasing, pillows should be evaluated for effectiveness of decontamination by routine washing and by disinfection when required. Like mattresses, pillows should be inspected regularly and replaced when necessary. In addition, during ongoing outbreaks in high-risk areas, such as burns units, it may be advisable to use disposable pillows.<sup>18</sup>

### Duvets

Duvets with a waterproof outer surface and covered with an outer fabric cover that can be laundered, are now used in many hospitals.<sup>1</sup> They are generally not recommended for incontinent or acutely ill hospital patients. Similar methods of decontamination apply as for mattresses and pillows.

### Linen

Linen can rapidly become heavily contaminated with colonised skin scales and may contribute to the spread of infection.<sup>14,50</sup> Although it is suggested that frequent changing is of limited value, and could contribute to increased aerial dispersal, evidence of the impact of frequent changing on transmission of infection is lacking.<sup>1,14</sup> Sheets and pillow covers should be changed at least twice weekly and when wet, soiled, stained, wrinkled, and if contaminated with potential infectious fluids.<sup>1</sup> Bed linen, including sheets, pillow cover, blankets, and the fire blanket should be changed on discharge of the patient. Linen should be laundered according to national or other standards, and stored in designated clean linen storage presses, reserved solely for clean linen.<sup>50,55,61,62</sup> Trolleys for holding linen prior to bed making should be clean and kept separate from contaminated items or materials.

### Accessory bed items

There are few if any reports of accessory items being contaminated, probably because these were not specifically assessed. Notwithstanding this, the risks are the same as for the hospital bed. Therefore all accessory items, such as bed cradles, hoists, should be kept clean and the decontamination measures should be similar to the bedframe.<sup>1,2</sup>

## Microbiological sampling of beds

In the absence of thermal disinfection or other adequate means of decontamination, periodic sampling may be indicated where surveillance shows that there is an increase in potential pathogens, or where antibiotic-resistant bacteria are especially prevalent. In such circumstances, the focus should be on the constant contact areas such as mattresses and pillows for MRSA, VRE or other antimicrobial-resistant organisms, and in high-risk units such as the ICU, burns, oncology and renal units, and where prosthetic implantation (e.g. artificial hip replacement) is a feature of that particular clinical area. Whilst experimental studies using test organisms on mattresses and pillows used for patients or even healthy members of the public pose ethical dilemmas, the screening of a mattress or pillow after decontamination may yield information on infection reservoirs and also establish the effectiveness of decontamination. Sampling techniques include the use of contact plates or sweeping the agar plate across the surfaces and must allow for any residual disinfectant. A traceability system, e.g. numbering of beds or mattresses, should be in place to allow follow-up of positive screening and to institute repeat decontamination of beds, if necessary.

## Conclusion

While designated a low-risk item, it is clearly evident that the hospital bed poses a potential risk of infection to patients if not adequately decontaminated. In addition, the possibility arises that contamination can occur during use on the same patient, especially during bed making or when large surgical sites or broken areas of skin are being dressed. Therefore regular, e.g. weekly, decontamination is advised. The ideal would be to decontaminate the bed by thermal disinfection between patients. Institutions, especially acute hospitals with endemic MRSA and VRE, should consider investing in this type of equipment or at least endeavour to ensure that the critical components, e.g. mattresses and pillows, are processed in a thermal disinfection unit. Other technology such as hydrogen peroxide should be studied further to determine its role for routine use as well as during outbreaks. Clear guidelines should be formulated for bed decontamination and systems established, such as labelling, to indicate when a bed has undergone decontamination. Pillows and mattresses should be made of materials that are easily washed, dried and

decontaminated, and have the lowest potential to harbour organisms. The regular replacement of mattress and pillows should be included in hospital budgets. While all equipment and environmental aspects in contact with the patient can cause infection, and therefore require appropriate decontamination, priority should be given to mattresses and pillows, due to their greater degree of contact with the patient.

## Conflict of interest statement

E. Creamer reports no conflict of interest.  
H. Humphreys is in receipt of research funding from Steris Ltd and 3M.

## Funding sources

There has been no funding for this study.

## References

1. Ayliffe GAJ, Fraise AP, Geddes AM, Mitchell K. *Control of hospital infection. A practical handbook*. 4th edn. London: Arnold; 2000.
2. AWMF Working Group for Hygiene in Hospital and Practice. *Hygienic processing of hospital beds. Krankenhaushygiene, Hygiene in hospital and practice*. 3rd edn. Wiesbaden: MHP-Verlag; 2005. 157–161.
3. Scales JI, Lowthian PT, Poole AG, Ludman WR. 'Vaperm' a patient-support system: a new general purpose hospital mattress. *Lancet* 1982;**2**:1150–1152.
4. O'Connor H. Decontaminating beds and mattresses. *Nurs Times* 2000;**96**:4–5. NTplus:2.
5. Rutala WA, Weber DJ. New disinfection and sterilization methods. *Emerg Infect Dis* 2001;**7**:348–353.
6. Scheidt A, Drusin LM. Bacteriologic contamination in an air-fluidized bed. *J Trauma* 1983;**23**:241–242.
7. Freeman R, Gould FK, Ryan DW, Chamberlain J, Sisson PR. Nosocomial infection due to enterococci attributed to a fluidized microsphere bed. The value of pyrolysis mass spectrometry. *J Hosp Infect* 1994;**27**:187–193.
8. Weber DJ, Rutala WA. The role of environmental contamination in the transmission of vancomycin-resistant enterococci. *Infect Control Hosp Epidemiol* 1997;**18**:306–309.
9. Boyce JM, Potter-Bynoe G, Chenevert C, King T. Environmental contamination due to methicillin-resistant *Staphylococcus aureus*: possible infection control implications. *Infect Control Hosp Epidemiol* 1997;**18**:622–627.
10. Bonten MJ, Hayden MK, Nathan C, et al. Epidemiology of colonisation of patients and environment with vancomycin-resistant enterococci. *Lancet* 1996;**348**:1615–1619.
11. Overton E. Bedmaking and bacteria. *Nurs Times* 1988;**84**:69–71.
12. Ensor E, Humphreys H, Peckham D, Webster C, Knox AJ. Is *Burkholderia (Pseudomonas) cepacia* disseminated from cystic fibrosis patients during physiotherapy? *J Hosp Infect* 1996;**32**:9–15.
13. Sexton T, Clarke P, O'Neill E, Dillane T, Humphreys H. Environmental reservoirs of methicillin-resistant *Staphylococcus aureus* in isolation rooms: correlation with patient

- isolates and implications for hospital hygiene. *J Hosp Infect* 2006;**62**:187–194.
14. Shiomori T, Miyamoto H, Makishima K, *et al.* Evaluation of bed-making-related airborne and surface methicillin-resistant *Staphylococcus aureus* contamination. *J Hosp Infect* 2002;**50**:30–35.
  15. Panagea S, Winstanley C, Walshaw MJ, Ledson MJ, Hart CA. Environmental contamination with an epidemic strain of *Pseudomonas aeruginosa* in a Liverpool cystic fibrosis centre, and study of its survival on dry surfaces. *J Hosp Infect* 2005;**59**:102–107.
  16. Sherburn RE, Jenkins RO. Aerial release of bacteria from cot mattress materials and the sudden infant death syndrome. *J Appl Microbiol* 2005;**98**:293–298.
  17. Ayliffe GA, Beard MA. A system of air recirculation and antibacterial surface treatment in a surgical ward. *J Clin Pathol* 1962;**15**:242–246.
  18. Mottar R, Roth M, Allen M, Gerber R, Jeffers BR. Pillow talk: examining pillow cores in a regional burn center. *Am J Infect Control* 2006;**34**:E107–E108.
  19. Loomes S. Is it safe to lie down in hospital? *Nurs Times* 1988;**84**:63–65.
  20. Woodcock AA, Steel N, Moore CB, Howard SJ, Custovic A, Denning DW. Fungal contamination of bedding. *Allergy* 2006;**61**:140–142.
  21. Pulvirenti JJ, Gerding DN, Nathan C, *et al.* Difference in the incidence of *Clostridium difficile* among patients infected with human immunodeficiency virus admitted to a public hospital and a private hospital. *Infect Control Hosp Epidemiol* 2002;**23**:641–647.
  22. Wilcox MH, Fawley WN, Wigglesworth N, Parnell P, Verity P, Freeman J. Comparison of the effect of detergent versus hypochlorite cleaning on environmental contamination and incidence of *Clostridium difficile* infection. *J Hosp Infect* 2003;**54**:196–201.
  23. French GL, Otter JA, Shannon KP, Adams NM, Watling D, Parks MJ. Tackling contamination of the hospital environment by methicillin-resistant *Staphylococcus aureus* (MRSA): a comparison between conventional terminal cleaning and hydrogen peroxide vapour decontamination. *J Hosp Infect* 2004;**57**:31–37.
  24. De Andrade D, Angerami EL, Padavani CR. A bacteriological study of hospital beds before and after disinfection with phenolic disinfectant. *Rev Panam Salud Publica* 2000;**7**:179–184.
  25. Martinez JA, Ruthazer R, Hansjosten K, Barefoot L, Snyder DR. Role of environmental contamination as a risk factor for acquisition of vancomycin-resistant enterococci in patients treated in a medical intensive care unit. *Arch Intern Med* 2003;**163**:1905–1912.
  26. Byers KE, Durbin LJ, Simonton BM, Anglim AM, Adal KA, Farr BM. Disinfection of hospital rooms contaminated with vancomycin-resistant *Enterococcus faecium*. *Infect Control Hosp Epidemiol* 1998;**19**:261–264.
  27. Noskin GA, Stosor V, Cooper I, Peterson LR. Recovery of vancomycin-resistant enterococci on fingertips and environmental surfaces. *Infect Control Hosp Epidemiol* 1995;**16**:577–581.
  28. Eckstein BC, Adams DA, Eckstein EC, *et al.* Reduction of *Clostridium difficile* and vancomycin-resistant *Enterococcus* contamination of environmental surfaces after an intervention to improve cleaning methods. *BMC Infect Dis* 2007;**7**:61.
  29. Noyce JO, Michels H, Keevil CW. Potential use of copper surfaces to reduce survival of epidemic methicillin-resistant *Staphylococcus aureus* in the healthcare environment. *J Hosp Infect* 2006;**63**:289–297.
  30. Weernink A, Severin WP, Tjernberg I, Dijkshoorn L. Pillows, an unexpected source of *Acinetobacter*. *J Hosp Infect* 1995;**29**:189–199.
  31. Denton M, Wilcox MH, Parnell P, *et al.* Role of environmental cleaning in controlling an outbreak of *Acinetobacter baumannii* on a neurosurgical intensive care unit. *J Hosp Infect* 2004;**56**:106–110.
  32. Catalano M, Quelle LS, Jeric PE, Di Martino A, Maimone SM. Survival of *Acinetobacter baumannii* on bedrails during an outbreak and during sporadic cases. *J Hosp Infect* 1999;**42**:27–35.
  33. Sherertz RJ, Sullivan ML. An outbreak of infections with *Acinetobacter calcoaceticus* in burn patients: contamination of patients' mattresses. *J Infect Dis* 1985;**151**:252–258.
  34. Kniehi E, Becket A, Forster DH. Bed, bath and beyond: pitfalls in prompt eradication of methicillin-resistant *Staphylococcus aureus* carrier status in healthcare workers. *J Hosp Infect* 2005;**59**:180–187.
  35. Rampling A, Wiseman S, Davis L, *et al.* Evidence that hospital hygiene is important in the control of methicillin-resistant *Staphylococcus aureus*. *J Hosp Infect* 2001;**49**:109–116.
  36. Blythe D, Keenlyside D, Dawson SJ, Galloway A. Environmental contamination due to methicillin-resistant *Staphylococcus aureus* (MRSA). *J Hosp Infect* 1998;**38**:67–69.
  37. Rahman M. Epidemic methicillin-resistant *Staphylococcus aureus* (EMRSA): experience from a health district of central England over five years. *Postgrad Med J* 1993;**69**(Suppl. 3):S126–S129.
  38. Moore EP, Williams EW. A maternity hospital outbreak of methicillin resistant *Staphylococcus aureus*. *J Hosp Infect* 1991;**19**:5–16.
  39. Ndawula EM, Brown L. Mattresses as reservoirs of epidemic methicillin-resistant *Staphylococcus aureus*. *Lancet* 1991;**337**:488.
  40. Fujita K, Lilly HA, Kidson A, Ayliffe GA. Gentamicin-resistant *Pseudomonas aeruginosa* infection from mattresses in a burns unit. *Br Med J* 1981;**283**:219–220.
  41. Robertson MH, Hoy G, Peterkin IM. Anti-static mattress as a reservoir of pseudomonas infection. *Br Med J* 1980;**280**:831–832.
  42. O'Donoghue MA, Allen KD. Costs of an outbreak of wound infection in an orthopaedic ward. *J Hosp Infect* 1992;**22**:73–79.
  43. Hammami A, Arlet G, Ben Redjeb S, *et al.* Nosocomial outbreak of acute gastroenteritis in a neonatal intensive care unit in Tunisia caused by multiply drug resistant *Salmonella wien* producing SHV-2 beta-lactamase. *Eur J Clin Microbiol Infect Dis* 1991;**10**:641–646.
  44. Sexton T, Creamer E, Turley M, Smyth EG, Humphreys H. Persistent environmental reservoirs for vancomycin-resistant enterococci requiring repeated decontamination to achieve eradication. *Br J Infect Control* 2002;**3**:10–13.
  45. Lai KK, Kelley AL, Melvin ZS, Belliveau PP, Fontecchio SA. Failure to eradicate vancomycin-resistant enterococci in a university hospital and the cost of barrier precautions. *Infect Control Hosp Epidemiol* 1998;**19**:647–652.
  46. Noble MA, Isaac-Renton JL, Bryce EA, *et al.* The toilet as a transmission vector of vancomycin-resistant enterococci. *J Hosp Infect* 1998;**40**:237–241.
  47. Peto R, Calrow A. An audit of mattresses in one teaching hospital. *Prof Nurse* 1996;**11**:623–624, 626.
  48. Hospital Infection Control Practice Advisory Committee (HICPAC). Recommendations for preventing the spread of vancomycin resistance. *Am J Infect Control* 1995;**23**:87–94.

49. Carling PC, Briggs J, Hylander D, Perkins J. An evaluation of patient area cleaning in 3 hospitals using a novel targeting methodology. *Am J Infect Control* 2006;**34**:513–519.
50. Bureau-Chalot F, Piednoir E, Camus J, Bajolet O. Microbiologic quality of linen and linen rooms in short-term care units. *J Hosp Infect* 2004;**56**:329–331.
51. Clarke P, Humphreys H. Persistence of vancomycin-resistant enterococci (VRE) and other bacteria in the environment. *Irish Med J* 2001;**94**:227–228.
52. Patel S. Minimising cross-infection risks associated with beds and mattresses. *Nurs Times* 2005;**101**(Suppl):52–53.
53. Centers for Disease Control and Prevention/Healthcare Infection Control Advisory Committee (HICPAC). *Guidelines for environmental infection control in health-care facilities*. Atlanta, GA: Centers for Disease Control and Prevention; 2003. p. 1–235.
54. Centers for Disease Control and Prevention/Healthcare Infection Control Advisory Committee (HICPAC). *Guideline for isolation precautions: preventing transmission of infectious agents in healthcare settings 2007*. Atlanta, GA: Centers for Disease Control and Prevention; 2007. p. 1–219.
55. Department of Health. Hospital mattress assemblies: care in cleaning. London; Department of Health: 1991. *Saf Action Bull* 1991;**91**:65.
56. Medical Devices Agency. Foam mattresses: prevention of cross-infection. London; Medical Devices Agency: 1999. *Saf Action Bull* 1999;**31**(Sept).
57. Irish Medicines Board. *Foam mattresses: prevention of cross-infection. Safety Notice*, Reference: VR-54. Dublin: Irish Medicines Board; 2002.
58. Dharan S, Mourouga P, Copin P, Bessmer G, Tschanz B, Pittet D. Routine disinfection of patients' environmental surfaces. Myth or reality? *J Hosp Infect* 1999;**42**:113–117.
59. National Hospital's Office. *National cleaning manual*. Dublin: National Hospital's Office; 2006.
60. Barker J, Vipond IB, Bloomfield SF. Effects of cleaning and disinfection in reducing the spread of norovirus contamination via environmental surfaces. *J Hosp Infect* 2004;**58**:42–49.
61. NHS Executive. *Hospital laundry arrangements for used and infected linen*. HSG(95)18. London: HMSO; 1995.
62. Barrie D. How hospital linen and laundry services are provided. *J Hosp Infect* 1994;**27**:219–235.